

PLEASE READ CAREFULLY

- ❖ **Kindly print this Bidding / Tender Document, read carefully, fill, sign & stamp on each page and submit with the technical quotation.**
- ❖ Participating bidders are required to submit bids according to the instructions mentioned in this Invitation to Tender (IT). These bids should meet the requirements / criteria illustrated in this IT along with fulfillment of other terms and conditions of the tender.
- ❖ According to PPRA rule 31, no bidder is allowed to alter or modify his bid after the bids have been opened. Moreover, as per rule 36 (b/vi), no amendment in the Technical Proposal is permitted during the technical evaluation. Therefore, in the light of prevailing Govt procedures, requests for amendments in quotations and clarifications leading to change of substance of bid after opening of bids cannot be accepted and bids not conforming to tender requirements are liable to be rejected.
- ❖ Participating bidders are therefore requested to read the bidding document thoroughly and submit their quotes accordingly without any condition in conformance to all tender requirements including Bid / Quote Validity, Delivery Period, provisioning of 10% Bank Guarantee confirmation etc. for consideration of bid. Bid found non-conforming to tender requirements is liable to be rejected on tender opening date.
- ❖ **Participating firms are to provide particulars of their representative supposed to attend tender opening on behalf of the firm on Phone No. 051-9099-2534 at least 01 day prior to tender opening.**

INDEX

CONTENTS
LIST OF CLAUSES AND ANNEXURES GENERAL PARTICULARS

<u>CLAUSE</u>	<u>TITLE</u>
1.	Invitation
2.	Condition Governing Contracts
3.	Delivery of Tender. (Single Stage Two Envelope Basis)
4.	Form PACB-002A & PACB-002B
5.	Single / Multiple Offers
6.	Date & Time for Receipt of Tender
7.	Delivery Period
8.	Rights Reserved
9.	Addition and Deletion of Store
10.	Validity of Quotation
11.	Technical Literature, Specifications and Interchangeability
12.	Deviation from Specifications
13.	Packing
14.	Restriction of Export / Import License
15.	Application of Official Secret Act 1923
16.	Examination of Specification / Samples
17.	Quoting of Prices
18.	Prices
19.	Country of Manufacture
20.	Disqualification
21.	Payment
22.	Documents Required
23.	Security Deposit / Bank Guarantee
24.	Inspection / Acceptance of Stores
25.	Checking of Store
26.	Tender Opening
27.	Withdrawal of Offer
28.	Treasury Challan
29.	Sequence of Quotation

30. Fax Quotation
31. Bid Security
32. Force Majeure
33. Arbitration
34. Litigation
35. Risk Purchase
36. Late Delivery
37. Authority to Sign Documents
38. Registered Supplier with FBR
39. Termination of Contract
40. Discrepancy
41. Prior Intimation Regarding Submission of Quotation
42. Bidding Clarifications to Tender
43. Response Time
44. Secrecy
45. Non-Disclosure Agreement

ANNEX "I"	SCHEDULE OF STORES
ANNEX "II" Form PACB-002A	SCHEDULE OF TENDER
ANNEX "III" Form PACB-002B	UNDER TAKING
ANNEX "IV" Form PACB-002C	QUESTIONNAIRE TO BE FILLED IN BY BIDDER
ANNEX "V" Form PACB-002D	SPECIAL INSTRUCTIONS
ANNEX "VI"	GENERAL CONDITIONS FOR BG



**GOVERNMENT OF PAKISTAN
MINISTRY OF DEFENCE PRODUCTION
PAKISTAN AERONAUTICAL COMPLEX KAMRA**

**INVITATION TO TENDER & GENERAL INSTRUCTIONS TO BIDDERS
(SINGLE STAGE TWO ENVELOPE BASIS)**

(F O R)

Tender No. PACB/751-A/161024042/1245/P-2

Directorate of Central Procurement

Pakistan Aeronautical Complex,

Kamra, District Attock

Tel: +92-051-90990-2543, 2534

Email: adcpre2@pac.org.pk

07 December, 2024

To,

[PPRA & PAC Websites](#)

Dear Sir,

1. **Invitation.** I invite you to tender for supply of [stores](#) details in the attached **Schedule to Tender** (Form PACB-002A)

2. **Condition Governing Contracts.** The “Contract” made as a result of this Tender Inquiry shall mean the agreement entered into between the parties i.e. the “Purchaser” and the “Seller” on PACB Contract Form (PACB–003) in accordance with the Law of Contract Act, 1872 and those contained in PAC purchase procedures with other special conditions that may be added to given contract for the supply of PAC stores specified therein.

3. **Delivery of Tender (Single Stage Two Envelope Basis).**

(a) **Technical Offer.** It shall contain all relevant specifications along with essential literature / brochure and properly filled Bidding Document duly signed and stamped on each page. “**Technical Offer without Prices**, Tender Number and Date of Opening” should be clearly marked on the face of envelope.

(b) **Commercial Offer.** It shall indicate prices quoted in figures as well as in words. “**Commercial Offer with Prices**, tender number and date of opening” should be clearly marked on the face of envelope.

(c) **Bid Security.** Tender number should be clearly marked on the back side of the Bid Security along with firm’s stamp & signature. It shall be sealed in an envelope separate from technical & financial bids.

(d) All three “**Envelopes**” should be enclosed in one cover, properly sealed, bearing the address of Directorate of Central Procurement (DCP), PAC, Kamra with “tender number and opening date”.

4. **Form PACB-002A & PACB-002B.** Form **PACB-002A (Annex ‘II’)** and **PACB-002B (Annex ‘III’)** duly filled-in are to be returned with the offer duly signed by the authorized signatory person.

5. **Single / Multiple Offers.** Only one offer can be made in relevant currency for same item. Multiple rates, if quoted, will be rejected. Multiple quotations against the tender will also be rejected.

6. **Date & Time for Receipt of Tender.** The tender must reach DCP PACB Kamra by the date and time specified in the Schedule to Tender (PACB – 002A attached). Tenders received after the prescribed date and time will, NOT be entertained. The appointed time will, however fall on next working day in case of closed/forced holiday. Telegraphed / Faxed / Telexed bids will be rejected unless specifically asked for. Tender can also be sent through courier however you are required to intimate this office (DCP) regarding dispatch of quotation through courier giving details of the courier through fax so that courier service may be tracked to ensure your participation in the Tender. In case tender is dispatched by courier then same should reach DCP, PAC at least 01 day prior to tender opening date. You or your representative may also attend the proceeding (Name / Designation of attendees’ along with copy of CNIC will be required 01 working day prior to tender opening date for arranging their entry).

7. **Delivery Period.** Stores are required within minimum possible delivery period **but not later than 120 days after signing of the contract.** Offers with minimum delivery period are likely to be preferred. However, delivery period is to be factual as no extension will be subsequently granted except under unavoidable circumstances beyond control of SELLER or under Force Majeure for which intimation with full justification / evidences is to be dispatched well in advance for consideration.

8. **Rights Reserved.** PAC Kamra reserves the right to accept or reject any tender and to annul the tendering process and reject all tenders at any time prior to contract award as per rule 33 of PPRA rules 2004 without thereby incurring any liability to the affected Bidder. Moreover, past performance of the firms may also be considered.

9. **Addition and Deletion of Store.** The purchaser has the right to increase or decrease the quantity of any item and cancellation of the contract partially or fully without any financial repercussion on either side without assigning any reason within 30 days of signing the contract. Such information will be passed on to the supplier / seller through the fastest means e.g. telephone, telegram or fax etc.

10. **Validity of Quotation.** The quotation must be **valid till 30 June, 2025** from the date of opening the tender.

11. **Technical Literature, Specifications and Interchangeability.** Offers are to be submitted in duplicate supported by brochures and technical literature in original. Offers must conform to tender specifications. A certificate of complete interchangeability must be endorsed on the quotation for all substitute or in-lieu items, otherwise the same are likely to be rejected. A copy of relevant page of publication must be attached to prove

correctness of offered / interchangeable / in-lieu item. Prices of master, substitute and in-lieu items must be quoted separately. **For any query regarding technical issues, firms may contact for any query regarding technical issues, firms may contact Tel Ext 051-90990-5893 or Directorate of Logistics, AMF (JF-17) PAC Kamra District Attock. Email: ddlogjf17amf@pac.org.pk.**

12. Deviation from Specifications. Stores received at consignee, if found not conforming to the contract specifications will be rejected and replacement in accordance with contractual specifications against rejected stores would be provided to consignee as per delivery schedule laid down in the contract. The replacement will be provided without any additional cost. In case stores are rejected after delivery schedule of the contract, replacement is to be provided at the earliest or by the date advised by Directorate of Central Procurement PAC.

13. Packing. Stores must be dispatched in standard trade packing unless otherwise specified to protect them against any damage. Any loss/damage caused due to poor packing will be recovered from the Supplier. In case items are shipped through sea, packing shall be sea worthy.

14. Restriction of Export / Import License. Offer subject to restriction of Import/Export License will not be entertained.

15. Application of Official Secret Act 1923. All matters connected with this inquiry and subsequent actions arising thereafter fall within the scope of the Pakistan Official Secret Act 1923 which forbid providing contractual information to un-authorized / un-concerned person / organization. It is therefore, requested to ensure complete secrecy regarding documents and stores concerned with the inquiry to limit the number of employees having accesses to this information.

16. Examination of Specification / Samples. When sealed pattern of stores are mentioned in the "Schedule to Tender" these may be seen at the place stated in the schedule and should be examined by you, or competent person on your behalf before the submission of tender.

17. Quoting of Prices. Prices are to be quoted as follows: -

(a) FOR price of the stores (Line Item Wise).

(b) The prices must be stated for each item separately both in figures and words. Additional information if any must be linked with entries on the Schedule to Tender (Form PACB-002A).

(c) Shelf / installation life of each item (if applicable) is to be mentioned separately.

18. Prices. The prices quoted must be per unit of issue / accounting unit as shown in the "Schedule to Tender" inclusive of sales tax/excise duty and surcharges. The breakdown of taxes/excise duty is to indicated separately. The prices must be stated for each item separately both in figures and words in Pak currency. Over writing / erasing in prices will be rejected. Mention GST separately.

19. **Country of Manufacture.** Country / place of manufacture of stores is to be provided along with offer.

20. **Disqualification.** Offers are liable to be rejected if: -

- (a) There is deviation from any instruction described in this invitation to tender.
- (b) Offers are found conditional or incomplete in any respect.
- (c) Multiple quotations against the tender.
- (d) Multiple rates are quoted against one item.
- (e) Manufacturer relevant brochure is not attached (in case of equipment or major assemblies of equipment).
- (f) Form PACB-002A, PACB-002B & PACB-002C duly filled – in and signed by the Bidders are not received with the offer.
- (g) Offer received later than appointed date and time.
- (h) Tender specification if not conforming to the offer. In case of equipment/ major assemblies manufacturer's brochures shows specifications different from those given in tender.
- (j) Offer subject to restriction of Export License.
- (k) Over writing / erasing in prices.
- (l) Change in prices by the supplier after opening of commercial offers unless asked by Directorate of Central Procurement PAC.
- (m) Validity of offer is not quoted as required in IT or made subject to confirmation later.
- (n) Offers not accompanied with prescribed tender / Challan fee of Rs. 200/-
- (p) Bid Security not provided.
- (q) Offer with Prior sale condition.
- (q) **Complete IT Document dully filled, signed and stamped on each page by authorized signatory of the firm not provided.**

21. **Payment.** 100% on CRV's with 10% Performance Bank Guarantee.

22. **Documents Required.** Following information's / copies of document must be provided with Tender: -

- (a) **Complete IT Document duly filled, signed and stamped on each page by authorized signatory of the firm.**

- (b) Photo copies of valid registration and indexation of foreign principal with PACB/DGDP applicable to the store / equipment offered.
- (c) A copy of letter showing firm's financial capability. Bank statement for last 01 year and other details to ascertain financial capability of firm.
- (d) Copies of audited accounts of the company for the last two accounting years that are prepared in accordance with the International Accounting Standards (IAS).
- (e) Photo copies of General Index number (GID), National Tax number (NTN), Sales Tax registration certificate. Foreign firms are required to provide copy of the company's valid Tax Compliance certificate issued by Revenue Authority of the domiciled country, valid as at the tender closing date.
- (f) Documentary evidence of the company's registration details / Certificate of Incorporation (Legal structure) by a recognized body in the domiciled country. Registration number issued by respective Department of Commerce or concerned department authorising to deal in subject store and export of store.
- (g) List and evidence of certification from recognized international bodies like ISO.
- (h) List of major clients and references (complete with names of contact persons, address and telephone numbers) of which the company has supplied similar items in the last 05 years. Number of years in the business or dealing in similar items may also be mentioned.
- (j) Firm/Supplier name, complete address, contact numbers, and email addresses.
- (k) Undertaking that their firm and their proprietors have not been in litigation/blacklisted by any Govt./Semi-Govt/Autonomous body.
- (l) Any other document if required during procurement proceedings according to Rule 17 of PPRA rules 2004.

Note: Security clearance of firm is mandatory before participation in tender. Firms having applied for security clearance or those intend to apply for security clearance soon after tender date can also participate in tender after submission of following additional documents. However, firm will be required to apply for security clearance immediately after tender submission: -

- (m) In case of foreign supplier photocopy of resident card, passport or equivalent identification card of person signing the tender is to be provided along with 02 passport size photographs.
- (n) Local agents / firms have to submit the copy of CNIC and 02 passport size photographs of person signing tender.

(p) Letter of authorisation from the Manufacturer confirming that the bidder is authorized to deal with the item quoted.

23. Security Deposit / Bank Guarantee. To ensure timely and correct supply of stores / services, the firm shall furnish an unconditional bank guarantee (BG) from a scheduled bank of Pakistan for an amount 10% of the contract value on a judicial stamp paper of the value of (Rs 100.00) as per prescribed format in the currency same as of contract. The bank guarantee shall be endorsed in favour of CMA (DP) Rwp who is the accounts officer specified in the contract. CMA (DP) Rwp have the like power of seeking encashment at site of the bank guarantee as if the same has been demanded by the purchaser himself. The bank guarantee shall be submitted by the supplier within 30 days of Contract signing and will remain valid for up to 60 days after completion of warranty period and remain in force till one year ahead of the date given in the contract. If period of contract is extended, the supplier shall arrange the extension of bank guarantee within 30 days after the original period to keep its validity always one year ahead of the extended period.

24. Inspection / Acceptance of Stores.

(a) Stores will be accepted at firm's premises / consignee by the inspector / Inspection officer of the PAC.

(b) As per format, [Warranty/Guarantee for a period of 01 year](#) will be applicable for stores commencing from the acceptance of store / installation at consignee.

25. Checking of Store. Store will be checked at consignee in the presence of representative of Supplier if he arrives within 15 days after initiation of letter.

26. Tender Opening. Only authorized person of firm will be allowed to attend tender opening.

27. Withdrawal of Offer. If the firm withdraws its offer or backs out from providing items won by the firm within validity period at any stage of contract finalization, the Competent Authority may place such firm under Embargo for a period of six months, which may extend up to one year / forfeit the earnest money.

28. Treasury Challan. Offer must be accompanied with a challan form of RS 200/- (obtainable from State Bank of Pakistan / Government Treasury) and debit able to **Major Head C02501-20, Main Head 12, Sub Head 'A' Miscellaneous (Code Head 1/845/30)**. Only one offer can be made for same item on one Challan. Multiple offer / rates, if quoted will be rejected.

29. Sequence of Quotation. Quotation must be prepared according to the item serial no sequence of Schedule to Tender (Form **PACB-002A**).

30. Fax Quotation. Fax / Email quotations will not be accepted except when specifically called for under emergency / urgency, however, Fax / Email quotation, if received will only be considered subject to condition that original Performa invoice for each quotation is received within 7 days of Tender Inquiry opening or as advised by procurement agency. In case original quotation is not received within specified time, the offer will be excluded from the competition without any notice to bidder.

31. Bid Security. The Bid Security @ 5% (**not exceeding 0.200 M**) will be deposited by all firms. Bid Security will be deposited in favour of **CMA (DP) Rwp** in the form of CDR / Pay order / Demand draft only at the time of tenders opening (with technical quotation), in a separate envelope. Bid Security will be returned to all firms except three commercially lowest bidding firms on finalization of commercial quotes. Whereas, Bid Security to the 2nd and 3rd commercially lowest bidders will be returned on signing of the contract. Bid Security of the contract concluding firm will be returned on submission of bank guarantee and on receipt of performance bank guarantee acceptance certificate from CMA (DP) Rwp. Quotations once submitted cannot be withdrawn (Partially/Fully) during validity of the quotation. Firms not complying with the said instructions would be liable for disciplinary action beside forfeiture of the earnest money.

Note: - No Quote will be accepted without Bid Security which will be as per IT clause 31. However, Bid Security must be provided in shape of CDR / Pay order / Demand draft only otherwise your quotation will be rejected.

32. Force Majeure. “Force Majeure” means any event, act / or other circumstances not being an event, act or circumstances, under the control of the Purchaser or of the Seller. The Seller will notify the Purchaser in writing of any such event within 15 days by Fax/Telex/Telegram of its commencement, which is relied upon by the Seller for its failure to comply with its obligation. The Purchaser have the right to conduct investigations to satisfy itself about the genuineness of the “Force Majeure” event non-availability of raw material for the manufacture of stores, or of export permit for the export of the contracted stores from the country of its origin, not constitute “Force Majeure”.

33. Arbitration. All matters of dispute or difference, except regarding rejection of stores / Services by the inspector and or cancellation of the contract by the Purchaser arising out of this contract between the parties hereto, settlement of which is not otherwise specifically provided for in this contract, be referred for adjudication to two arbitrators, one to be nominated by each party. Deputy Chairman PAC, Kamra will be nominated Arbitrator from PAC. The Arbitrators, before entering on the reference appoint an umpire by mutual consent, and if they do not agree, a judge of the superior court will appoint the umpire. The arbitration proceedings will be held in PAC Kamra under Pakistani Law. The Arbitration award shall be unspoken.

34. Litigation. The “Seller” is restricted, not to take the matter in any court of law and not to disclose the matter by mass communication through any mode. In case of any dispute, only Court of Jurisdiction at Attock has the Jurisdiction to decide the matter.

35. Risk Purchase. In the event of failure on the part of the Seller to comply with the contractual obligations, the contract is liable to be cancelled at his risk and expense in accordance with General Condition Governing Contracts.

36. Late Delivery. If the Supplier fails to deliver any or all of the Goods by the Date(s) of delivery or perform the Related Services within the period specified in the Contract, the Purchaser may take following actions: -

- (a) Cancel the contract, and/or.
- (b) To purchase from elsewhere stores not delivered, at the risk and expense of the Supplier and without notice to him, or

(c) To recover liquidated damages when the Competent Purchase Officer is satisfied that the failure to supply the stores / services within the scheduled delivery period has been for reasons within the control of the Supplier, and/or if the Government has suffered loss for reasons of belated delivery. These liquidated damages, if imposed, will be recovered at the rate of up to 2% but not less than 1% (depending on the merit of the case as decided by Competent Purchase Officer) of the value of stores / service supplied late per month or a part of a month for the period exceeding the original delivery period, subject to the provision that the total liquidated damages thus imposed will not exceed 10% of the total value of the stores / services delivered late.

(d) The purchaser's decision under this clause shall NOT be subjected to arbitration.

37. Authority to Sign Documents. Tender must be accompanied by Letter of Authorization to sign the Tender on behalf of the Bidder. Bidder must prove that the person who signs this Tender is fully authorized to bind his establishment / company. Such proof shall be in the form of clear official documents fully legalized by designated authorities in respective countries.

38. Registered Supplier with FBR.

(a) Only registered supplier who are on Active Taxpayers List (ATL) of FBR eligible to supply goods / services Government Department.

(b) The payment to the registered persons will be linked with the active taxpayer status of the suppliers as per FBR database if any registered supplier is not in ATL his payment should be stopped till he files his mandatory returns and appears on ATL of FBR.

39. Termination of Contract. The purchaser shall be entitled to terminate this contract for default on the part of supplier. If the supplier becomes bankrupt, or have a receiving order made against him, or compound with his creditors, or being a corporation commences to be wound up, not being a member's voluntary winding up for the purpose of reconstitution or amalgamation, or carries on its business under a receiver for the benefit of its creditors.

In case the Purchaser elects to terminate this Contract, the Purchaser shall give notice in writing to the Supplier to make good the default. Should the Supplier fail to initiate proceedings in order to comply with the notice within 15 days from the date of serving of such notice, the Purchaser may forthwith terminate this contract by notice in writing to the Supplier without prejudice to any rights which may have occurred there under to either PARTY prior to such termination. Termination of the Contract shall be without prejudice to any right of arbitration under the contract hereafter.

If the supplier delays delivery of any Equipment to be supplied to the Purchaser under this Contract for more than 21 (twenty-one) days from the time specified for delivery, there of or, 15 days for any extension of subsequent delays then the purchaser reserve the right to terminate this contract without prior notice to the supplier and purchase from elsewhere (other firm or country) stores not delivered, at the risk and expense of the supplier. However, intimation to such a cancellation would be affected by registered letter

sent to be supplier and without need to legal or judicial or other formalities. In addition, the purchaser will have the right to recover any loss or damage or payment made to the supplier.

Upon termination the Supplier shall refund all such payments for which goods and/or services have not been delivered or rendered. The Supplier shall refund the amount due with interest at 1% above the Libor rate.

40. Discrepancy. The consignee will render a discrepancy report within 90 days after receipt of the material in Pakistan for any discrepancy found in consignment and shortage in quantities for which the seller is responsible to replace short quantity free of cost. If the seller is unable to provide the replacement for the rejected store / short quantities within 90 days, the seller will make a complete refund of any payment received against the rejected store / short quantities to the purchaser. In case of surplus supply by the seller, the purchaser will render to the seller the material delivered in excess at seller's expense. Discrepancy report regarding loss/damage will be immediately lodged with the seller/carrier. Reasonable time be provided to the purchaser to inspect the store. The seller will co-operate with purchaser in filling claims with the carrier. In case the stores on checking / test after receipt at consignee's warehouse are found not conforming strictly to the contract specification and other particular, the Seller shall immediately replace the rejected store by acceptable store free of cost and without any obligation to the Purchaser. If the seller is unable to provide the replacement for the rejected store within 90 days, the seller will make a complete refund of any payment received against the rejected store to the purchaser. Rejected stores will be disposed off by the Seller under his own arrangements within 14 days from the date of rejection and within 72 hours in case of dangerous, infected and perishable stores. In case the seller fails to lift the stores within the above-mentioned stipulated period he will pay storage charges at the following rates. Moreover, the purchaser shall not be responsible or accountable for the safety or security of the rejected stores if not lifted by the seller after the stipulated time period: -

Cost of the Stores Storage Charges

(a)	Up to Rs. 1 M	5% per Annum
(b)	Above 1 and up to 5 M	4% “ “
(c)	5 to 10 M	3% “ “
(d)	Over 10 M	2% “ “

41. Prior Intimation Regarding Submission of Quotation. To avoid misplacement of the quotations, all firms are required to intimate this office regarding dispatch of their quotation through courier giving details of the courier through telephone, / email, so that courier service may be tracked to ensure your participation in the competition.

42. Bidding Clarifications to Tender. In case any clarification is required regarding tender, firm may contact on following address however, queries in regards to the tender shall only be entertained till one week prior to the deadline for submission of tenders.

Technical Clarification. Directorate of Logistics, AMF (JF-17) PAC Kamra District Attock Tel Ext 051-9099-5893 Email ddlogjf17amf@pac.org.pk.

Bidding / Contracting Procedure. Directorate of Central Procurement PAC Kamra Tel No 051-9099-2534 Email: adcpre2@pac.org.pk.

43. Response Time. Firms are requested to provide only valid email and telephone numbers for contact and addressing technical queries. It is further highlighted that during TSR due to limited time, firms are requested to respond / reply to queries within time specified in letter/ email in soft and hard copies. In case of late or nil reply/ feedback, that item(s) having query will be rejected without any justification and subsequently will not be entertained at any stage.

44. Secrecy. The name of PAC Kamra should never be disclosed in any form as client. The contract document be kept confidential / secret and must not be shared / mishandled along with no scanning / photocopy etc and violation would be liable for punitive legal actions including cancellation of contract & confiscation of BG / EM etc.

45. Non-Disclosure Agreement. At contract signing stage the firm will provide Non-Disclosure Agreement on stamp paper of Rs. 100/-. The sample of the same will be provided at the time of contract signing.

Yours sincerely,

(JAM BADAR)
Squadron Leader
Asstt Dir Cent Proc
PAC, Kamra
Tel Ext: 051-9099-2534

SCHEDULE OF STORES

Tender Inquiry No : PACB/751-A/161024042/1245/P-2
 TENDER SUBMISSION TIME : Before 1030 Hrs on opening date
 TIME & DATE OF OPENING : 1100 Hrs on 24 December, 2024

Note: No further extension in opening date will be granted except under extreme circumstances.

PROCUREMENT OF ENCODERS & MOTION CONVERTOR FOR SHEET STRETCH FORMING MACHINE

S No	Part No	Noun	U/I	Qty
1	SWF10B-01	Cable Type Displacement Converter	Ea	1
2	KRD58S8192R4 096Z01-ZKD01	Absolute Encoder KRD 58 Series	Ea	3
3	SWH 3-01	Cable Type Displacement Converter SWH Series (3 Meter)	Ea	1
4	SWH 2-01	Cable Type Displacement Converter SWH Series (2 Meter)	Ea	1

Specification of Cable Type Displacement Converter

S.No	Description	Specification / Range
1	Part No	SWF10B-01
2	Range	10 M
3	A=Total length	187 MM
4	B=Cable center to edge distance.	67
5	C=	100
6	D=Hole sizes and grade.	2x M8,8 Deep
7	Mass (Kg)	4
8	V max @ T = 20c°. Cable speed	12m/s
9	a _{max} @ T = 20c°. Cable accelaration	60m/s ²

Note: Drawing attached for reference.

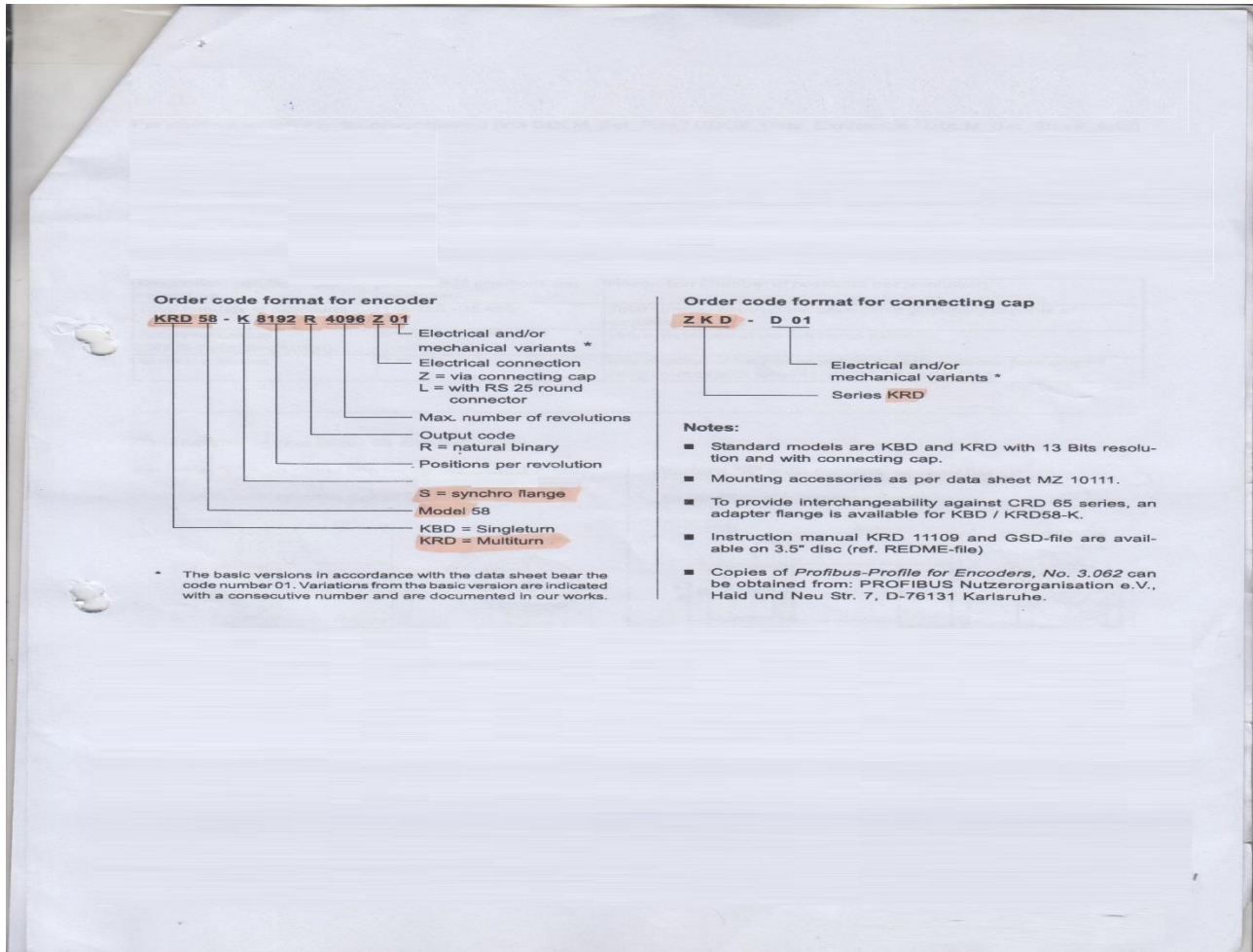

Specification of Absolute Encoder KRD 58 Series

S.No	Description	Specification / Range
1	Part No	KRD58S8192R4096Z01-ZKD01
2	Design from Model	(KRD) Multi-Turn
3	Variant	Electrical / Mechanical
4	Connecting Cap	Z type (ZKD-D01)
5	No of Revolutions	4096
6	Out Put Code	R Natural Binary
7	Position per revolution	4096 Steps / 360 8192
8	Housing Material	Stainless Steel 1.4305
9	Flange	58 S (Synchro Flange)

Note: Drawing attached for reference.

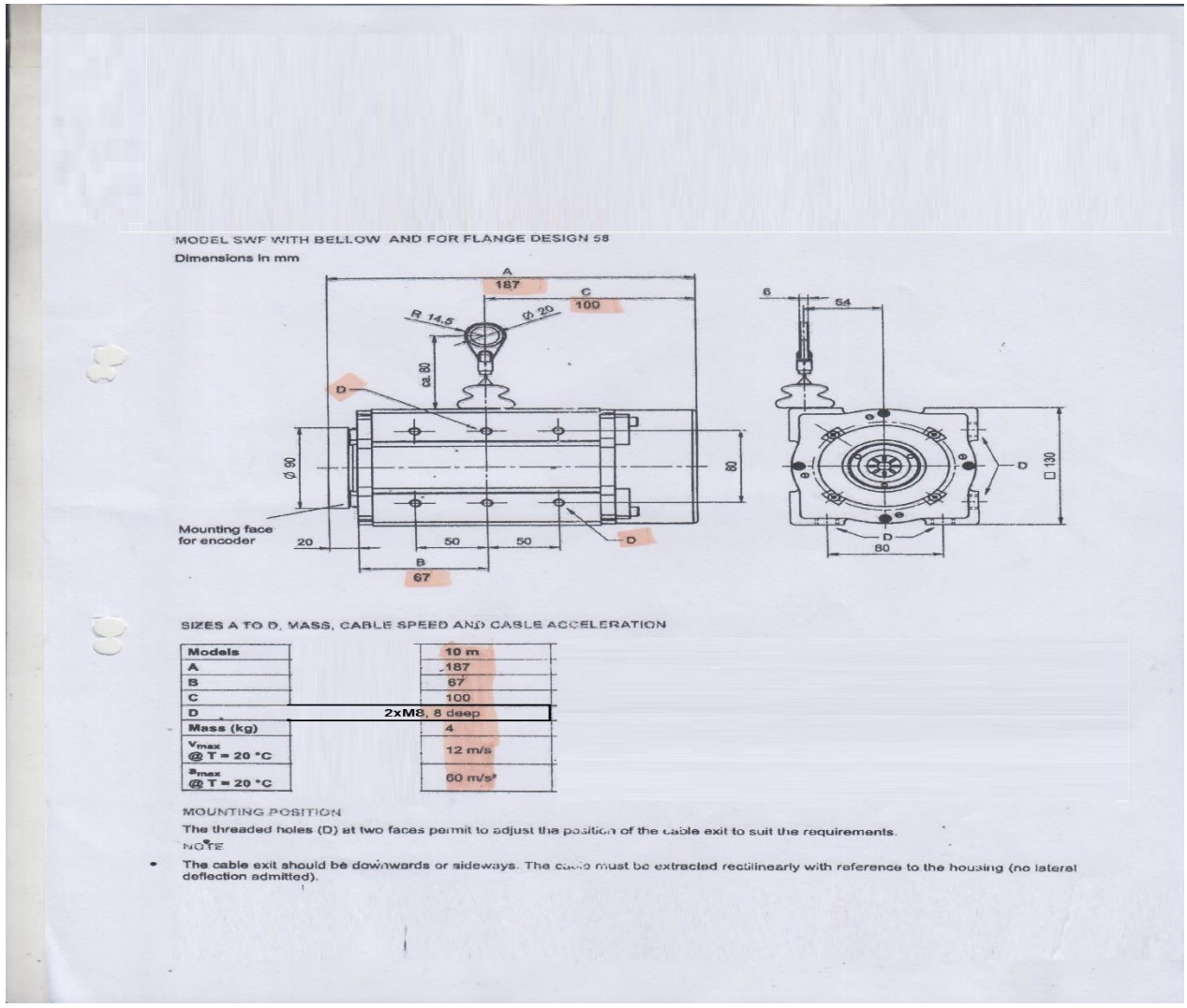

Specification of Cable type Displacement Converter SWH Series (2 Meter)

S.No	Description	Specification / Range
1	Part No	SWH 2-01
2	Measuring Range	2 Meter
3	Circumference of Cable Drum	200 mm
4	Housing Material	IP65
5	Basic Version for Flange Model 58	1
6	Belows at Cable Entry	B

Note: Drawing attached for reference.

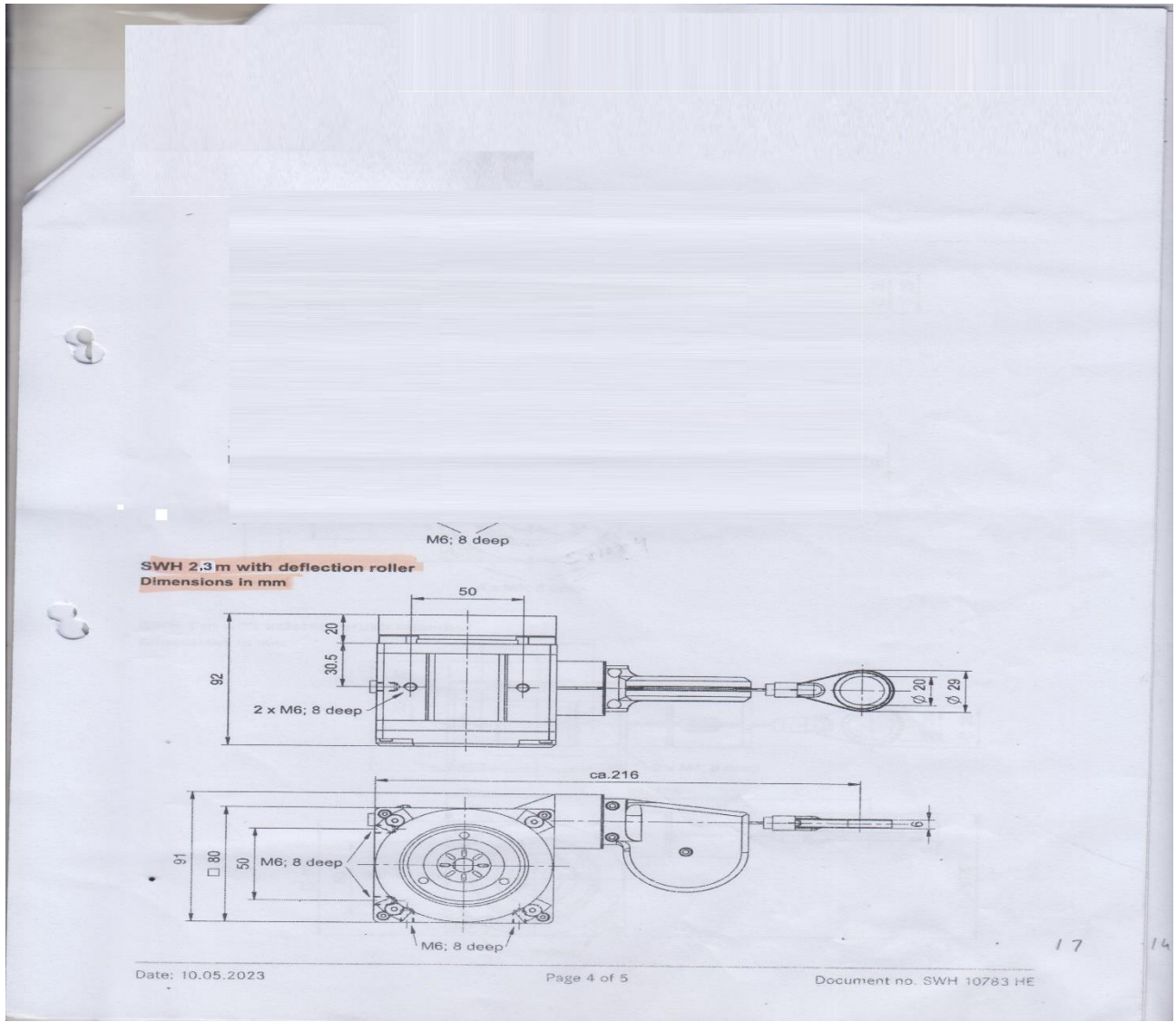

Specification of Cable type Displacement Converter SWH Series (3Meter)

S.No	Description	Specification / Range
1	Part No	SWH 3-01
2	Measuring Range	3 Meter
3	Circumference of Cable Drum	200 Mili Meter
4	Housing Material	IP65
5	Basic Version for Flange Model 58	1
6	Belows at Cable Entry	B

Note: Drawing attached for reference.

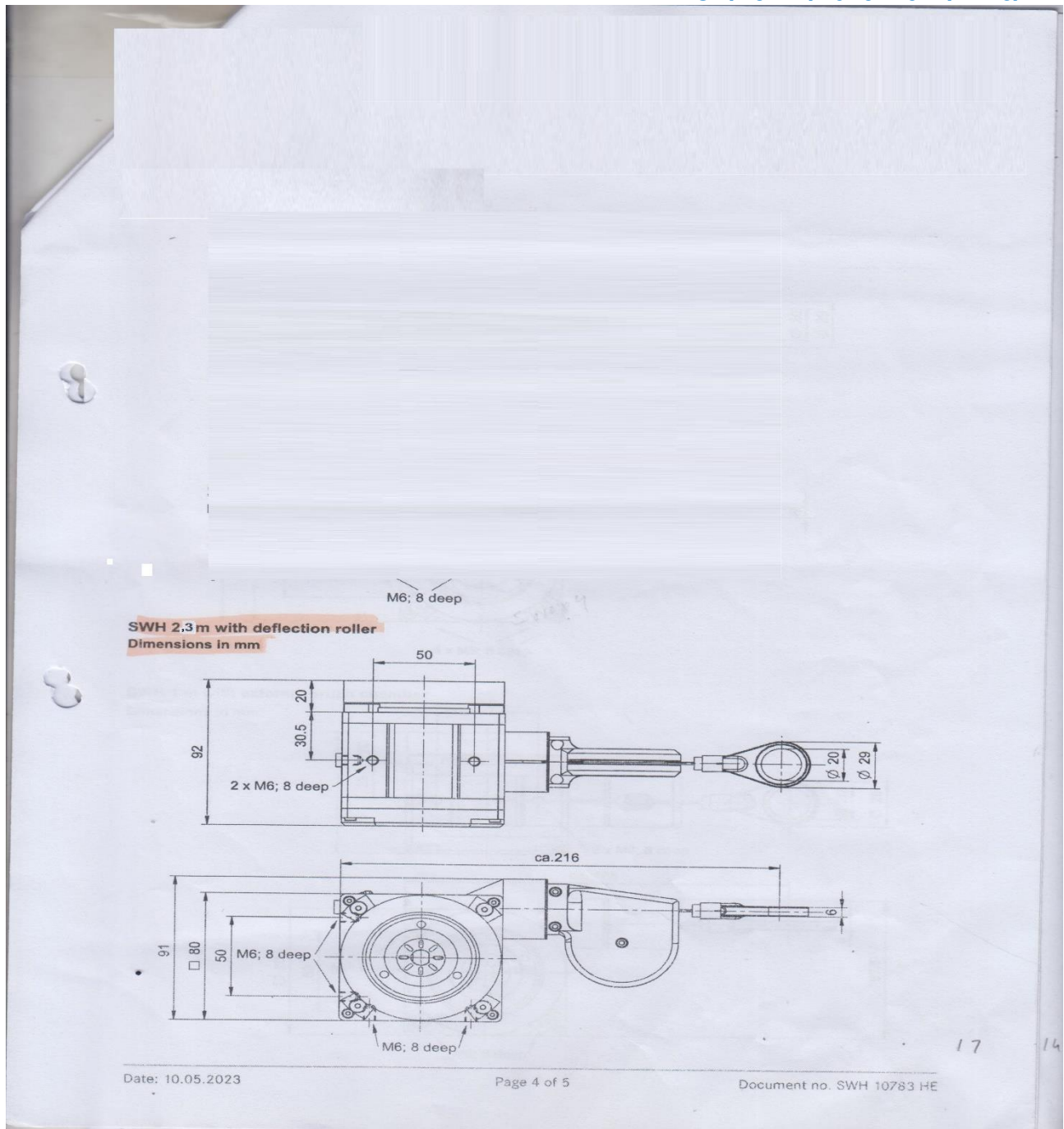

Notes

1. Quotation must be submitted on '**FOR KAMRA BASIS**'.
2. Inspection will be carried out by Quality Control of AMF after receipt of store at AMF as per AMF quality procedures.
3. Store should be delivered in standard OEM packing on FOR Kamra basis.
4. The packing should clearly indicate name/code of product, name of manufacturer.
5. CoC of OEM / authorized dealer will be provided with stores.
6. 01 year standard warranty is required to be provided.
7. Items should be factory new.

PAKISTAN AERONAUTICAL COMPLEX, KAMRA**SCHEDULE TO TENDER**

1. Tender Inquiry No. **PACB/751-A/161024042/1245/P-2**
2. Time & Date of Tender opening is at **1100 Hrs on 24 December, 2024. (No further extension in opening date will be granted except under extreme circumstances).**

(1)	(2)	(3)	(4)	(5)	(6)
Item No	Description of stores and specifications	Unit of issue	Qty	Price per unit	Total price

Grand Total_____

Signature of Tenderer
(Capacity in which signing)

Annexure "III" (Form PACB-002B)

UNDER TAKING
(Fill in and Return)

To,

Member Commercial
Pakistan Aeronautical Complex
Kamra Distt Attock

Dear Sir,

I/We hereby offer to supply to PAC the stores detailed in the Schedule to Tender or such portion thereof as you may specify in the contract at the prices given in Form **PACB-002A (Annexure 'II')** and further agree that this offer will remain valid up to _____ and will not be withdrawn or altered in terms of rates quoted and the condition stated therein on or before this date. I/We shall be bound by your communication of acceptance to be dispatched within the prescribed time.

I/We understood the instructions to Tenders and condition of contract as laid down in Form **PACB-10** titled "**General Conditions Governing Contract**" and thoroughly examine specification / drawing and / or patterns quoted in the Schedule to Tender and am/are fully aware to the nature of the stores required and my/our offer is to supply stores strictly in accordance with the requirements.

Yours faithfully

Witness's Signature:

Name:

N.I.C No.

Address:

Signing:

Date:

Signature of Tenderers:

Name:

N.I.C No.

Capacity in which

Address:

Date:

Tele:

Telex/Fax:

Annexure “IV” (Form PACB-002C)

QUESTIONNAIRE TO BE FILLED IN BY BIDDER

Firm is required to provide confirmation of following points and in case of any change, same is to be highlighted in remarks column.

S No	Description	Yes / No	Remarks
1.	Whether stores offered conform to the specification and confirmation to this effect has been made in the quotation given in Form PACB – 002A .		
2.	Whether deviation from the demanded specification is attached with Form PACB – 002A .		
3.	Whether complete quotation has been submitted in duplicate.		
4.	Whether the prices are exclusive of taxes/duties if so whether taxes/duties have been shown separately.		
5.	Whether Form PACB–002A & 002B duly filled in and signed by the Bidder have been returned in herewith.		
6.	Whether copy of valid registration / business authorization of firm have been enclosed herewith.		
7.	Whether tender fee challan amounting to Rs 200/- has been enclosed herewith.		
8.	Whether details of financial capability (Bank Statement etc.) and financial load of contracts outstanding against your firm have been provided.		
9.	It is confirmed that no Taxes / Duties & Dues payable to Pakistan Govt are outstanding at the part of vendor / firm.		
10.	Copy of NTN or Equivalent Tax compliance Certificate (for foreign firms) has been attached.		
11.	It is confirmed that firm and their proprietors have not been in litigation / blacklisted by any Govt./Semi-Govt / Autonomous body		
12.	Unit Price has been provided against same unit of issue as mentioned in IT. In case of change in unit of issue, price has been converted as per ITs unit of issue in a separate column along with conversion formula		
13.	All requisite documents as per Para 22 of Invitation to tender have been attached.		
14.	10% PBG will be provided at the time of signing of contract		
15.	Warranty period will be provided for required period.		
16.	Letter of Authorization to sign Tender Documents on behalf of firm has been attached.		
17.	Offer is without any condition		
18.	Complete IT Document dully filled, signed and stamped on each page by authorized signatory of the firm is provided.		

Dated: _____

(Signature of Bidder & Stamp)

SPECIAL INSTRUCTIONS

Under mentioned information must be provided along with quotation else your quotation will be rejected: -

S No.	Description / Requirement	Remarks / Attached
1.	Delivery Period.	
2.	Warranty period.	
3.	Quotation Validity up to 30-06-2025 from the date of opening the tender.	
4.	Terms of Payment (As per Para 21 of IT).	
5.	BG% (Confirmation to provide 10% BG).	
6.	Complete Bank address and Account Details For Payment.	
7.	Previous Experience (Nature of Business and No of Years in Business).	
8.	Registration Status with PAC.	
9.	Signing Authority (Name, Designation, Contact Details).	
10.	Address of firm along with contact No, email etc.	

Annexure 'VI'

GENERAL CONDITIONS FOR BG

- (a) To ensure timely and correct supply of stores, the firm will furnish an unconditional Bank Guarantee within 30 days of the signing of the contract from a schedule Bank for an amount of Rs _____ i.e. _____% of the total value of the contract (on a judicial Stamp paper of the value of Rs 100/-). The Bank Guarantee shall be endorsed in favour of CMA (DP) Rwp who is the Account Officer specified in the contract. The CMA (DP) Rwp concerned shall have the like power of seeking encashment of the Bank Guarantee as if the same has been demanded by the purchase officer himself.
- (b) The Bank Guarantees will be of following types with validity and amount has mentioned in each type
- (i) Bank Guarantee against contract performance. It will be 10% of total value of contract excluding taxes/duties and freight/handling charges etc. It shall remain enforce till 60 days beyond the Delivery Period stipulated in the contract.
 - (ii) Bank Guarantee against Advance/ Down Payment. It will be equal to amount paid in advance /down payment shall remain valid till 60-days beyond the Delivery Period stipulated in the contract.
 - (iii) Bank Guarantee against Warranty Period. It will be for amount 10% of contract value excluding taxes/duties and freight /handling charges, etc. Duration of BG against Warranty Clause is variable. Normally under DPL –15, it is for one year for the general type of equipment / spares. For consumable goods, the warrantee period should also expire after 6 months or when the goods are fully consumed whichever is earlier or as per terms of contract.
- (c) If the supply of store is on warranty, the supplier shall be bound to extend the validity of Bank guarantee for such further reasonable period if so, required by the purchase officer to cover the warranty period.
- (d) If the supplier fails to provide the Bank guarantee within 30 days after signing a contract, such failure shall constitute a breach of contract and the Director purchase shall be entitled to make other arrangements at the risk and expense of the supplier if no other BG / Bid Security of the same supplier for an equal amount is held up for final release, with the purchaser against any other completed contract(s). In the event of unsatisfactory performance or of any breach of terms of the contract, Bank guarantee shall be forfeited to the Govt. at the discretion of the purchaser. On satisfactory performance of the contract, the Bank Guarantee will be returned to the supplier by CMA (DP) Rwp on receipt of instruction from the purchaser i.e. Directorates of Procurements etc.
- (e) In case of FOR tenders / contract it is imperative that BGs are obtained from firms/suppliers/agents through scheduled Banks of State Bank of Pakistan so as to safeguard the interest of the state.
- (f) In case of FOB tenders / contracts, Bank Guarantee is to be obtained preferably from LC opening Bank of Pakistan and through supplier, LC opening Bank abroad. In case the firm does not agree to the aforesaid condition, then BG should at least, be obtained from supplier's country Bank located in Pakistan or any enlisted scheduled Bank of Pakistan in favour of LC opening Bank in Pakistan or any scheduled Bank of Pakistan, and the same will be a Bank to Bank Guarantee in favour of CMA (DP) Rwp.